

1 MATERIAL: MILD STEEL PLATE.

2. ALL DIMENSIONS ARE TO THEORETICAL SHARP.
3. REMOVE BURRS AND BREAK ALL SHARP EDGES .5 MAX.
4. ALL DIMENSIONS ARE IN MM UNLESS STATED OTHERWISE.
5. PARTS SHALL BE FREE OF GREASE AND CUTTING FLUID.
6. FINISH - BLACK OR WHITE STANDARD PAINTED FINISH.
7. FINISH - POWDERCOAT COLOURS OPTIONAL.
8. "X DIMENSION" - 200MM - 450MM STANDARD LENGTH, IN 50MM INCREMENTS. CUSTOM CUT LENGTHS AVAILABLE UPON REQUEST.

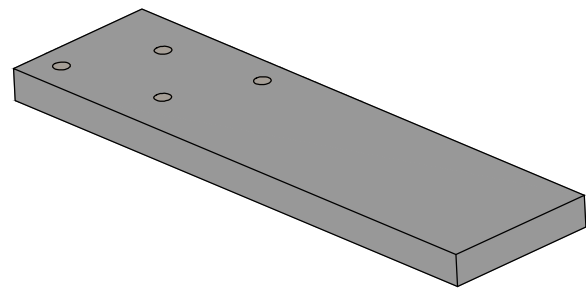
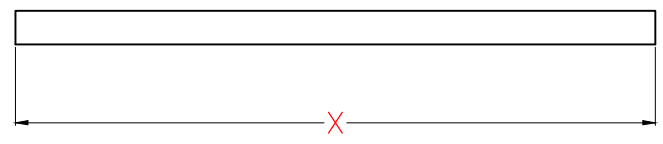
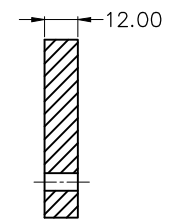
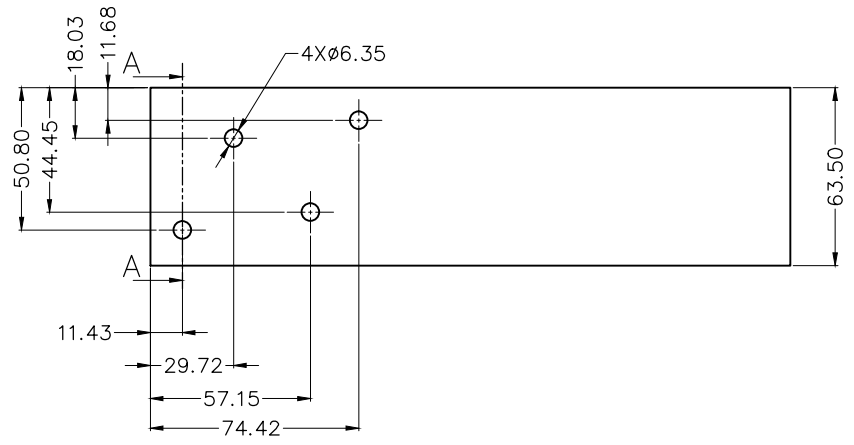

1 ISOMETRIC VIEW
FOR REFERENCE ONLY

TOLERANCES UNLESS OTHERWISE SPECIFIED	
WITHOUT DECIMAL AND FRACTIONS	± .50
WITH ONE DECIMAL	± .25
WITH TWO DECIMAL	± .15
WITH THREE DECIMAL	± .10



URBAN Metalwork + Design Studio
6 Kambouris Crt, Corio,
VIC, 3214
P | +61 432 590 125
E | info@urbanmetalwork.com.au
W | www.urbanmetalwork.com.au

These details are not to be used for construction purpose, details are to be used as a guide only. Each individual project need to be taken into account on its merits and discussed with Urban Metalwork for clarification of design and installation. This design detail is generic, commonly used system by Urban Metalwork but may not directly apply to all projects and circumstances. Please contact Urban Metalwork to discuss your specific requirement or for further design clarification.

Notes:
"X" is to be determined by the customer prior to fabrication.

Drawing Title
STANDARD COUNTERTOP BRACKET

	NAME	SIGNATURE	DATE
DRAWN			
CHECKED			
APPROVED			

Size.	Cage Code	Drawing No.	Rev.
			0

SCALE 1:1 3RD ANGLE Sheet 1 of 1